

STRICTLY CONFIDENTIAL

COPYRIGHT 1937

SERVICE MANUAL

FOR THE RECEIVER

TYP 30 A

FOR A.C. SUPPLY

GENERAL DATA.

This superhet receiver is equipped with:
 Seven tuned circuits.
 Filter for signals on intermediate frequency.
 Automatic volume control.
 Special noise-reducing H.F. penthode.
 Distorsion reduction by means of L.F. counter-coupling.
 Continuously regulable tone filter.
 Visual tuning by means of a tuning cross.
 Normal-foreign switch.
 Permantly-energised moving-coil speaker with built in sound diffusor. (type 9644).
 Connection for low-ohmic speaker.
 Connection for gramophone pick-up.
 Voltage change-over switch for voltages between 105 and 255 V.
 Safety contact.
 High- and low speed tuning by means of a push-pull-switch.

Knob-arrangement.

Left: larger knob	— tone control.
smaller knob	— volume control.
pushed in	— normal.
pulled out	— foreign.
Right: larger knob	— wave band selector and radio-gramophone switch.
smaller knob	— tuning knob.
pushed in	— coarse regulation.
pulled out	— fine adjustment.
Knob on left panel	— mains switch ¹⁾ .

Wave-ranges:

C2:	9.5— 16.5 m.	(31.5 — 18.2 Mc/s).
C1:	16.5— 48 m.	(18.2 — 6.25 Mc/s).
B :	48 —170 m.	(6.25— 1.76 Mc/s).
A :	170 —570 m.	(1760 — 525 kc/s).

Weight: 16.4 K.gr. (valves included)

Dimensions: height 37 cm.
 breadth 54 cm.
 depth 28.5 cm. (knobs included).

¹⁾ In some apparatus the mains-switch is controlled by the knob for the volume-control by turning it to the left as far as possible.

DESCRIPTION OF CIRCUITS

Waveband C2: (9.5-16.5m) (31.6-18.2 Mc/s).

Aerial coil: S₆, (inductively coupled with S₇).
Grid circuit of L1: S₇, C₆₀, tuning condenser C₃, trimmer C₄₇, coupling with L₁ via C₂₀.

Anode circuit of L1: S₁₄ (inductively coupled with S₁₅), series resistance R₃₇.

Grid circuit of L2: S₁₅, C₆₂, tuning condenser C₄, trimmer C₆. R₁₀ prevents parasitic oscillation of L₂.

Circuit of oscillatorgrid of L2: S₂₂, C₆₃, tuning condenser C₅, trimmers C₁₂ and C₆₄. Grid condenser C₂₅, grid leak R₇. R₆ prevents parasitic oscillation.

Coil of oscillatoranode of L2: S₂₃ (inductively coupled with S₂₂).

Waveband C1: (16.5-48 m) (18.2-6.25 Mc/s).

Aerial coil: S₈, inductively, and via C₆₅ capacitively coupled with S₉.

Grid circuit of L1: S₉, C₅₉, tuning condenser C₃, trimmer C₄₈.

Anode circuit of L1: S₁₆ (inductively coupled with S₁₇), series resistance R₂₄.

Grid circuit of L2: S₁₇, C₆₁ with shunt R₃₈, tuning condenser C₄, trimmer C₇.

Circuit of oscillatorgrid of L2: S₂₄, tuning condenser C₅, trimmer C₁₃.

Coil of oscillatoranode of L2: S₂₅, (inductively coupled with S₂₄).

Waveband B: (48-170 m) (6.25-1.76 Mc/s).

Aerial coil: S₁₀, inductively, and via C₆₆ capacitively coupled with S₁₁.

Grid circuit of L1: S₁₁, tuning condenser C₃, trimmer C₄₉.

Anode circuit of L1: S₁₈, inductively coupled with S₁₉.

Grid circuit of L2: S₁₉, tuning condenser C₄, trimmer C₈.

Circuit of oscillatorgrid of L2: S₂₆, C₂₇, tuning condenser C₅, trimmer C₁₄.

Coil of oscillatoranode of L2: S₂₇ (inductively coupled with S₂₆).

Waveband A: (170-570 m) (1760-525 Kc/s).

Aerial coil: S₁₂ (inductively coupled with S₁₃), C₅₃.

Grid circuit of L1: S₁₃, tuning condenser C₃, trimmer C₅₀.

Anode circuit of L1: S₂₀ (inductively coupled with S₂₁).

Grid circuit of L2: S₂₁, tuning condenser C₄, trimmer C₉.

Circuit of oscillatorgrid of L2: S₂₈, tuning condenser C₅, trimmer C₁₅, padding condenser C₄₃, trimmer C₁₀.

Coil of oscillatoranode of L2: S₂₉ (inductively coupled with S₂₈).

I.F. aerial filter: S₄₀-C₂₉. This filter shorts the aerial for signals of the I.F. to avoid whistling notes.

I.F. circuits:

1st band-pass filter: The anode circuit S₃₀-C₁₆ of L₂ is coupled via coil S₃₁ with the grid circuit S₃₂-S₃₁-C₁₇ of L₃.

2nd band-pass filter: The anode circuit S₃₃-C₁₈ of L₃ is coupled via the coil S₃₄ to the detector circuit S₃₅-S₄₁-S₃₄-C₁₉.

The anode of the detector diode is connected to a tapping of the coil in order to reduce damping along this circuit.

Detector circuit: First diode-anode of L₄, S₄₁, S₃₄, R₁₇, volume control R₁₉, R₃₆, R₁₃, cathode L₄; C₃₃.

L.F. amplifier: From the volume control R₁₉ the L.F. voltage is conducted via the condenser C₃₆ to the grid of L₄.

The amplified L.F. voltage over the coupling resistance R₂₁ passes via the coupling condenser C₃₈ on to R₂₅ and from there via R₃₅ to the grid of L₅. C₄₂ and C₄₅ serve for suppressing any possible residual I.F. voltage. R₃₅ and R₂₆ prevent L₅ oscillating.

Optical tuning indicator:

When tuning, the D.C. voltage across R₃₀ of the potentiometer R₂₉-R₃₀ passes to the triode section of L₁₀. As a consequence the anode current (the current through R₃₂), and so too the voltage difference across R₃₂, drops. The deflection plates in the tube connected to this anode then get a higher voltage, causing the screening effect to be reduced and the brightening cross to become wider. Tuning is correct when the greatest possible width has been reached.

Quality correction.

By leading back to the grid circuit of L₄ a part of the output voltage of L₅ it is achieved that the L.F. amplifier can deliver a greater power with less distortion. This leading back of the output voltage is effected as follows: The cathode resistance R₃₄-R₁₆-R₁₃ of L₅ is bridged by the condenser C₅₈, which allows high notes, but not low and middle notes to pass, so that over C₅₈ a voltage of low and middle notes is obtained. The middle notes are led back via C₅₇ (which holds back the low notes) - R₃₃-R₁₉ and C₃₆ to the grid of L₄ (in opposite phase with the original tension). The low notes are led back via R₃₄ and R₁₆ to the cathode (in phase) and via R₃₄-R₃₀-R₂₉-R₁₉-C₃₆ to the grid of L₄ (in opposite phase). This last part is controlled at the same time as the volume by R₁₉, in which way it is achieved that for each volume of sound the counter coupling works in the best manner.

Automatic volume control.

The rectified d.c. voltage across R₁₅ is conducted via S₃₁ and S₃₂ to the control grid of L₃ and via R₃ to the control grid of L₁, in which way the amplification of these valves is controlled.

Details of the circuit diagram.

The receiver is provided with a "normal-foreign" switch which is operated by pulling out or pushing in the knob of the volume control. In the "normal" position the grid bias of L1 and L3 is greater than in the "foreign" position (see "supply of the receiver") in which way the sensitivity of the set is reduced in the first position, so that only the stronger stations are audible and the set almost has no back ground noise between the tuning of two stations. In the "foreign" position the sensitivity of the set is as great as possible. In the wavebands C2 and C1 the oscillator frequency is 475 Kc/s lower than the tuning of the H.F. circuits. In the bands B and A the oscillator frequency is 475 Kc/s higher.

Supply of the receiver.

Power transformer : S1, S2, S3, S4.
 Rectifier : L6.
 Anti-hum condenser : C69.
 Smoothing filter : C1, S5, (R2), C2.

Va of L1: via R28; uncoupled by C37, C32.
 V3 of L1: via R28; uncoupled by C37, C32.
 V1 of L1: see below.

Va of L2: via R9, R28; uncoupled by C31.
 V3,5 of L2: via R5, R8; uncoupled by C24.
 V2 of L2: via R8; uncoupled by C30, C11.
 V4 of L2: tension across R4 + R39; uncoupled by C22.

V1 of L2: tension across R4.

Va of L3: tension on C2.

V2 of L3: from potentiometer R11, R12; uncoupled by C35.

V1 of L3: see below.

Va of L4: via R22, R21; uncoupled by C39.

V1 of L4: see below.

Va of diode of L4: see below.

Va of L5: tension on C2.

V2 of L5: via R26 (resistance to prevent parasitic oscillation).

V1 of L5: tension across R34 + R16 + R13; partly uncoupled by C58 (see "Quality correction").

V1 of L1, L3 and L4 and Va of diode of L4.

The d.c. of the set flowing through the resistance R2 delivers a d.c. tension across this resistance. In parallel to R2 are connected in the "normal" position the potentiometers R1, R18, R20 and R1, R15, R14, R17, R19, R36.

The controlgrid bias of L4 is delivered from the first potentiometer between R18 and R20. The controlgrid bias of L1 and L3 uncoupled by C34) and Va of the diode-anode of L4 (uncoupled for I.F. by C33) are delivered from the second potentiometer resp. between R15 and R14 and between R14 and R17.

In the "foreign" position the resistance R42 is switched in parallel to R14, R17, R19, R36, so that the controlgrid bias of L1 and L3 and Va of the diode-anode of L4 become less and the set becomes more sensitive.

Remark. The resistance R42 is switched between the oscillatoranode of L2 and the chassis to prevent alteration of the tension when switching from the "foreign"- to the "normal" position.

ADJUSTING THE RECEIVER.

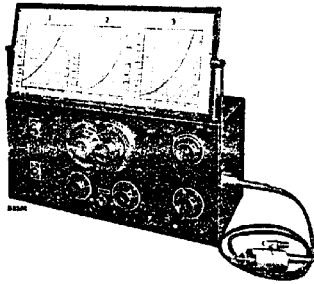

Fig.1

For adjusting the receiver it is not necessary to remove it from its cabinet. By placing the cabinet on its left side on a piece of felt and removing the bottom and rear plates all the points necessary for trimming are accessible.

Re-adjustment is necessary:

1. After changing coils or condensers in the I.F. or H.F. section.
2. When the set is not sufficiently sensitive or selective (see E-sheets).

When adjusting use:

1. Service oscillator GM 2880 (fig. 1).
2. Output indicator: Universal measuring apparatus 4256 or 7629.
3. Auxiliary receiver or aperiodic amplifier GM 2404.
4. Measuring pin for connection of the auxiliary set.
5. A 15° gauge for establishing the relation between condenser position and dial.
6. Trimming plug-in key 6 mm, without metal parts.
7. Insulated trimming plug-in key 6 mm.
8. Insulated trimming plug-in key 8 mm.
9. Insulated trimming screw-driver.
10. Wax for fixing the trimmers.
11. A condenser of $25 \mu\mu\text{F}$.
12. A condenser of $0.1 \mu\text{F}$.
13. A condenser of $32000 \mu\mu\text{F}$.
14. A trimming transformer.
15. A tuning tester.

Use as artificial aerial:

1. For I.F.: a condenser of $32000 \mu\mu\text{F}$.
2. For medium waves (170-570 m): a standard artificial aerial.
3. For short waves (9.5-170 m): a shortwave artificial aerial = red spot on standard artificial aerial.

Tuning tester.

When adjusting use a tuning tester. This instrument

consists of a rubber tube, inside which a piece of copper is fitted to one side and a piece of so-called H.F. iron to the other.

Successively the two ends are put into the hole at the bottom side of the coil. When the output indicator falls back in both cases the concerning circuit is well-tuned, otherwise it will have to be adjusted.

Trimming transformer.

If the plug-socket plate of the loudspeaker is provided with the letter A, a trimming transformer will have to be used between the set and the output-indicator.

Always use the customer's valves when trimming.

If during trimming the converter valve becomes defective then trim again (Pre-heat the new valve). Before proceeding to trim, the wax on the trimmers must be softened (for instance by means of a soldering iron).

Trim the set in the "foreign" position.

For the position of the trimmers see fig. 2.

I. I.F. circuits.

1. Connect grid 2 of L2 via $0.1 \mu\text{F}$ to earth.
2. Set the wavelength switch to band A (170-570 m).
3. Set the volume control and the variable condenser to maximum.
4. Connect the outputmeter to the speaker sockets.
5. Apply a modulated signal of 475 kc/s via $32000 \mu\mu\text{F}$ to grid 4 of L2.
6. Trim consecutively C19, C18, C17 and C16 to maximum output.
7. Remove the generator short-circuit and the condenser of $32.000 \mu\mu\text{F}$.
8. Seal the trimmers.

II. I.F. aerial filter.

1. Set wavelength switch to band A (170-570 m).
2. Set the variable condenser to maximum.
3. Apply a modulated signal of 475 kc/s via the normal artificial aerial to the aerial socket.

4. Shift the core of S40 until minimum output is obtained. (This core is to be found between the L.F.- and the H.F. chassis almost above the plug socket plate for aerial and earth).
5. Seal the trimmers.

III. H.F. and oscillator circuits.

Owing to the importance of the sections A and D (in the latter particularly ± 13 m) trimming in these sections is effected more precisely than in the others.

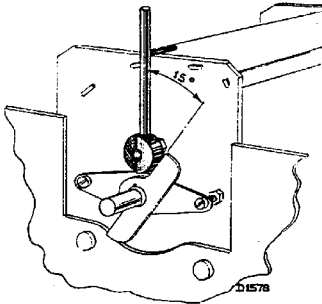

Fig. 4

Adjusting with harmonics.

When adjusting the receiver frequencies are needed, which are not furnished by the service-oscillator G.M. 2880. In this case the harmonics are used. This means that the oscillator is set at a wavelength which is two or three times the wanted wavelength. The exact harmonic is then filtered by the preselection of the set.

For the position of the trimmers see fig. 2.

Trim the set with the volume-control at maximum.

Band A: (170-570 m), (1760-525 kc/s).

1. Fit the 15° gauge (see fig. 4). Turn the variable condenser firmly against the gauge (smallest capacity).
2. Connect the outputmeter to the speaker sockets.
3. Apply to the aerial socket a modulated signal of 1650 kc/s. (182 m).
4. Trim C15, C9 and C50 to maximum output.
5. Short-circuit the generator circuit by interposing a condenser of 0.1 μ F between grid 2 of L2 and earth.
6. Connect the anode of L2 via a condenser of 25 μ F to the aerial socket of the auxiliary set. The outputmeter must be after the auxiliary set.
7. Set the service oscillator at 600 kc/s. (500 m).
8. Tune the auxiliary receiver.
9. Tune the receiver under test with the aid of the variable condenser.
10. Remove the connection of the auxiliary set

and the generator short-circuit. Place the outputmeter after the set to be trimmed.

Do not turn the variable condenser of the set to be trimmed.

11. Trim C10 to maximum output.
12. Fit the 15° gauge (see fig. 4). Turn the variable condenser firmly against the gauge (smallest capacity).
13. Apply to the aerial socket a modulated signal of 1650 Kc/s (182 m).
14. Re-trim C15.
15. Seal the trimmers.

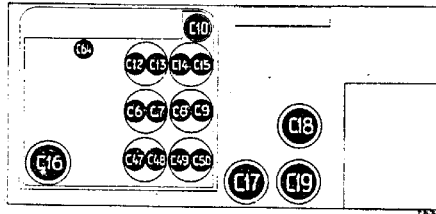

Fig. 2

Band B: (48-170 m), (6.25-1.76 Mc/s).

1. Fit the 15° gauge (see fig. 4). Turn the variable condenser firmly against the gauge (smallest capacity).
2. Connect the outputmeter to the speaker sockets.
3. Apply a modulated signal of 5.75 Mc/s (52.1 m) to the aerial socket.
4. Trim C14, C8 and dC49 to maximum output.
5. Seal the trimmers.

Band C1: (16.5-48 m) (18.2-6.25 Mc/s).

1. Fit the 15° gauge (see fig. 4). Turn the variable condenser firmly against the gauge (smallest capacity).
2. Short-circuit the generator circuit by interposing a condenser of 0.1 μ F between grid 2 of L2 and earth.
3. Connect the anode of L2 via a condenser of 25 μ F to the aerial socket of the auxiliary set. The outputmeter must be after the auxiliary set.
4. Apply a modulated signal of 17.4 Mc/s (17.2 m) to the aerial socket of the set to be trimmed.
5. Tune the auxiliary set.
6. Trim C48 and C7 to maximum output.
7. Remove the connexion of the auxiliary set and the generator short-circuit. Place the outputmeter after the set to be trimmed. Do not turn the variable condenser of the set to be trimmed.
8. Trim C13 to maximum output.
9. Seal the trimmers.

Band C 2: (9.5-16.5 m) (31.5-18.2 Mc/s).

1. Fit the 15° gauge (see fig. 4). Turn the variable condenser firmly against the gauge (smallest capacity).

2. Short-circuit the generator-circuit by interposing a condenser of $0.1 \mu\text{F}$ between grid 2 of L2 and earth.
3. Connect the anode of L2 via a condenser of $25 \mu\mu\text{F}$ to the aerial socket of the auxiliary set. The outputmeter must be after the auxiliary set.
4. Apply a modulated signal of 32 Mc/s (9.4 m) to the aerial socket of the set to be trimmed.
5. Tune the auxiliary receiver.
6. Trim C 47 and C6 to maximum output.
7. Remove the connection of the auxiliary set and the generator short-circuit. Place the outputmeter after the set to be trimmed.
Do not turn the variable condenser of the set to be trimmed.
8. Trim C12 to maximum output.
9. Short-circuit the generatorcircuit by interposing a condenser of $0.1 \mu\text{F}$ between grid 2 of L2 and earth.
10. Connect the anode of L2 via a condenser of $25 \mu\mu\text{F}$ to the aerial socket of the auxiliary set. The outputmeter must be after the auxiliary set.
11. Apply a modulated signal of 23 Mc/s (13.0 m) to the aerial socket of the set to be trimmed.
12. Tune the auxiliary receiver.
13. Tune the receiver under test with the aid of the variable condenser.
14. Remove the connection of the auxiliary set and the generator short-circuit. Place the outputmeter after the set to be trimmed.
Do not turn the variable condenser of the set to be trimmed.
15. Trim C64 to maximum output (with the trimming key without metal parts).
16. Fit the 15° gauge (see fig. 4). Turn the variable condenser firmly against the gauge (smallest capacity).
17. Apply a modulated signal of 32 Mc/s (9.4 m) to the aerial socket of the set to be trimmed.
18. Re-trim C12.
19. Seal the trimmers.

To adjust the tuning scale:

1. Connect the outputmeter to the L.S. sockets.
2. Apply a signal of 200 m (1500 kc/s) to the aerial socket and tune the receiver.
3. Set the pointer at exactly 200 m. with the aid of the screw that pinches the steel wire to the pointer.
4. Tune the receiver to signals of 350 m (858 kc/s) and 500 m (600 kc/s).
5. If the last two indications are not correct the driving drum must be shifted as shown in the table below.
6. Tune the receiver again to a signal of 200 m (1500 kc/s). If need be readjust the pointer and repeat the operations of 4 and 5.

	350 m.	500 m.	Direction of regulation plate
1	good	too high	↑ or ↖
2	good	too low	↙
3	too high	too high	←
4	too low	too low	→
5	too high	too low	↓
6	too high	good	↓
7	too low	too high	↑
8	too low	good	↑

TRACING FAULTS

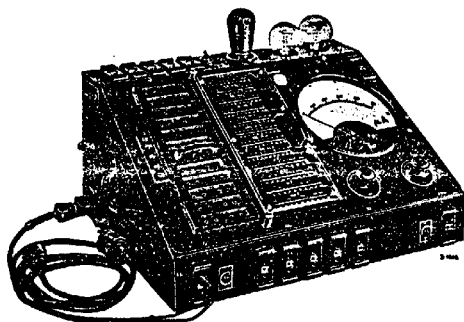

Fig. 5

For properly establishing defects a good measuring instrument is necessary; therefore always use the Universal Measuring Apparatus type 4256 (fig. 5) or 7629. To locate a fault it is not necessary to take the set out of its cabinet. By placing the set on its left side on a piece of felt and removing the bottom and back plates all parts are accessible. Do not unsolder a single connection before the defect has been located by measurement. The normal values of currents and voltages are mentioned between brackets. These values are measured with the measuring apparatus type 7629 or 4256.

I. Connect the set at the correct voltage and test its valves on the outdoor aerial or service-oscillator.

- a. If the set works normally leave it in operation and keep it in observation.
- b. If the set does not work at all, or badly, then:

II. Place a set of good valves from a properly functioning receiver in the set to be examined and if need be try another speaker. Faults in valves or speaker are thus eliminated or located.

III. Examine whether gramophone reproduction is possible.

- a. If reproduction is possible, then the fault lies in the I.F. or H.F. section (see under V).
- b. If no reproduction is possible then the fault must be sought in the feed or L.F. section (see IV or VI).

IV. No radio and no gramophone reproduction.

A. Voltage across C2 abnormal (normal 260 V).

1. Mains-voltage adapter in wrong position.
2. Mains-switch or safety contact defective (measure the voltage over the primary winding).
3. R2 defective
4. S5 defective
5. C2 short-circuited.
6. C1 short-circuited (measure).

7. C69 short circuited (measure the a.c. voltage between the anodes of L6.
8. S1, S2, S3 or S4 defective.
9. C37 or C32 short-circuited.
10. Short-circuit against the chassis in the screening tube of the 2nd I.F. transformer.
11. Short-circuit in the output transformer.
12. Interruption or short-circuit in one of the filament leads.

B. Voltage over C2 normal.

a. L5 has abnormal voltages and currents. (Normal: $i_a = 34$ mA, $i_s = 4.8$ mA.).

1. No anode current: S36, R13, R16, R34, R26 interrupted.
2. Anode current too high: C57, C58 short-circuited.
3. R25, R35 interrupted.

b. L4 has abnormal voltages and currents. Normal: $i_s = 0.8$ mA.

1. No anode current: R13, R21, R22 interrupted. C39, C42 short-circuited.
2. Anode current too high: C21, C36 short-circuited.
3. R1, R18, R20 interrupted.

c. L4 and L5 have normal voltages and currents but no gramophone reproduction.

1. S37, C36, C38 interrupted.
2. C45 short-circuited.
3. Fault in loudspeaker.

V. Gramophone reproduction, but no radio reception.

A. L3 has abnormal voltages and currents.

Normal: in "normal" position:

$$i_a = 4 \text{ mA}; i_s = 1 \text{ mA.}$$

in "foreign" position:

$$i_a = 8 \text{ mA}; i_s = 2 \text{ mA.}$$

1. No anode-current: S33, R12 interrupted; C35 short-circuited.

2. Anode current too high: C21, C34 short-circuited; R1 interrupted.
3. S31, S32, R15 interrupted.
- B. L2 has abnormal voltages and currents.**
Normal: $i_a = 0,7$ mA; $i_{s33} = 1.1$ mA; $i_s = 3$ mA.
- No anode-current: S30, R9, R28, R4, R39, R5 or R8 interrupted. C31, C32, C37, C30, C24 or C11 short-circuited.
 - Anode-current too high: C22 short-circuited.
 - R10, S15, S17, S19, S21, R38 interrupted.
- C. L1 has abnormal voltages and currents.**
Normal: In "normal" position:
 $i_a = 4$ mA. $i_s = 0.1$ mA.
In "foreign" position:
 $i_a = 8$ mA. $i_s = 0.2$ mA.
- No anode-current: R37, S14, R24, S16, S18, S20, R28, R27 interrupted; C37, C32 short-circuited.
 - Anode-current too high: C34, C20, C21 short-circuited.
 - R3, R15, R1, interrupted.
- D. L1, L2 and L3 have normal voltages and currents, but no radio-reception.**
- No reproduction of a modulated signal of 475 kc/s applied to the control grid of L3 via a condenser of 0,1 μ F, while the grid is earthed via 0,1 M.Ohm. C18, C19, C33, S33, S34, S35, S41 short-circuited or interrupted.
 - No reproduction of a modulated signal of 475 kc/s applied to the control grid of L2 via a condenser of 0,1 μ F, while the grid is earthed via 0,1 M.Ohm. C16, C17, S30, S31, S32 short-circuited or interrupted.
 - Reproduction of a modulated I.F. signal applied to the control grid of L2, but no reproduction of a H.F. signal on that grid.
Oscillator is not working.
 - In none of the ranges: C5, C25, R6, R7 interrupted or short-circuited.
 - In one of the ranges: Oscillator-coils or condensers of the concerning range interrupted or short-circuited.
 - Reproduction of a modulated H.F. signal applied to the control grid of L2, but not when applied to the control grid of L1.
 - In none of the ranges: C4, R10 interrupted or short-circuited.
 - In one of the ranges: Coils or condensers of the concerning range in the anode-wiring of L1 or the controlgrid wiring of L2 short-circuited or interrupted.
- 5. Reproduction of a modulated H.F. signal applied to the control grid of L1, but no radio-reception.**
- In none of the ranges: C3, C20, R3 interrupted or short-circuited.
 - In one of the ranges: Coils or condensers of the concerning range in aerial wiring or in controlgrid wiring of L1 interrupted or short-circuited.
- VI. Radio and gramophone reproduction - quality bad, however.**
- A. Reproduction too weak.**
- Abnormal voltages and currents.
 - Set out of adjustment - trim.
 - A fault in the speaker or speaker transformer.
 - C65, C66 interrupted.
 - Bad contact in normal-foreign switch.
- B. Distorted reproduction.**
- Valve defective.
 - Fault in the speaker.
 - Abnormal voltages and currents.
 - C57, C58, R33 interrupted.
- C. A.V.C. does not function.**
R14, R15 interrupted; C34 short-circuited.
- D. Optical tuning not functioning properly.**
- No light: lamp defective.
 - Light, but no alteration in the tuning cross: R29, R31, R32 interrupted; C51 short-circuited.
 - Alteration in the tuning cross too great: R30 interrupted.
- E. Insufficient selectivity.**
- Set out of adjustment- trim.
 - C16, C17, C18, C19 short-circuited: measure the resistance of the I.F. coils.
- F. Microphonic effect.**
- Fault in a valve.
 - Fault in the variable condenser.
 - The screws which hold the chassis during transport have not been loosened. These screws can be reached through the threaded sockets for fixing the chassis.
 - Wave-range switch or its shaft touch the cabinet.
- G. Hum.**
- Screenings not in contact with the chassis.
 - C1, C2, C21, C23, C69 interrupted.

3. S5 short-circuited.
In case of complaint use the 2nd anti-hum condenser (symmetrically to C69).
- H. Crackling.
Bad contact at a soldering spot or in a switch.
- K. The set oscillates.
One of the decoupling condensers interrupted: C2, C21, C22, C23, C24, C30, C31, C32, C34, C35, C37, C39, C42, C45.
- L. The set resonates.
This can be caused by loose parts, such as valve hoods, springs, clamps, etc. When the resonating part has been found it must be fixed with a piece of felt.

TRACING FAULTS BY THE „POINT-TO-POINT” SYSTEM

If a universal measuring apparatus type 4256 or 7629 is available the tracing of faults is greatly simplified by applying the “point-to-point” system. At the beginning this method is the same as that indicated in the E-sheets under points I and II. After this follows:

III. General examination according to the “point-to-point” system, i.e. measuring of resistance and capacity between valve holder contacts and connection sockets, both with respect to each other and with respect to the chassis. In this way a fault and, with the aid of the circuit diagram, the defective part can be traced. If need be compare with the E-sheets.

- a. Remove the mains flex from the plug socket.
- b. Remove all valves and place in the valve holder of the rectifier lamp a valve base with the contacts of filament and anodes interconnected. In this way, furthermore, the meter is protected against possible overloads on the smoothing condensers.
- c. Connect the universal measuring apparatus type 4256 or 7629 and set at resistance measurement (position 12). Lengthen the + pin of the measuring flex so that the contacts of the valve holder, etc. can easily be touched. Insert the other pin in the earth socket of the receiver.
- d. Measure the resistance between the points indicated in the point-to-point table and the chassis by touching the indicated contact by the + pin. Compare the meter deflection with the value in the table.

Note. P signifies: measure between the gramophone pick-up socket and earth, etc. 11/12 signifies: measure between points 11 and 12. 5 × 18 signifies: Measure at 5 positions of the waveband switch.

- e. Switch the measuring apparatus in succession on position 11, 10 and 9 and compare the readings.
- f. Set the universal measuring apparatus for capacity measurement (in succession on position 12, 11, 10 and 9). Compare the meter deflection with the value in the table.
- g. Remove the short-circuiting valve-base when measuring at the valve holder of the rectifier.

Important.

- I. The values measured can vary about 10% with those given in the table, without this necessarily pointing to a defective part.
2. During resistance measurements of electrolytic condensers the leak current and with it the meter deflection drops during measurement. Now it may happen that the value found is much too high owing to a defective condenser; however, such a deviation also occurs when the set has not been in operation for a long time. Be careful therefore when judging electrolytic condensers!

Number code for valve-holder contacts.

The first numeral indicates the valve holder in accordance with the circuit diagram, the second one has the undermentioned significance:

- | | |
|---------|-----------------------------------------------------------------------------|
| 1 and 2 | = filament |
| 3 | = control grid |
| 4 | = contact for metallisation |
| 5 | = cathode |
| 6 | = extra grid (for instance 1st grid of octode, suppressor grid of penthode) |
| 7 | = screen grid |
| 8 | = anode |
| 9 | = extra grid (for instance 2nd grid octode). |

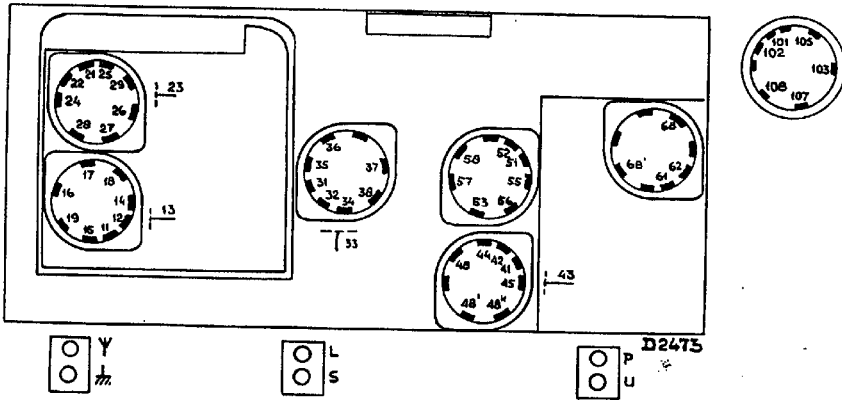

Fig. 6

RESISTANCE.

12	11/12	till	101/102	14 till 44			L/S	5 x 23					5 x Y				
	5	5	5	5	5	5	5	360	375	360	500	360	20	355	205	115	20
11	38	57	58	68	68'												
	355	375	410	375	375												
10	17	5 x 18					26	27	28	5 x 29					37	U ¹⁾	
	410	425	415	425	425	425	245	75	130	230	230	230	230	230	330	325	
9	13	23 ²⁾	33	43	48	48''	53	103	108								
	60	180	85	125	325	255	195	85	75								

CAPACITY.

12	13	43 ³⁾	43 ⁴⁾	48/53													
	85	190	265	375													
11	33	103															
	160	280															
10																	
9																	

Position waverange-switch 9.5—16.5 m.

- 1) Position: gramophone.
- 2) Position: 16.5—48 m.
- 3) Volume control at maximum.
- 4) Volume control at minimum.

REPAIR AND CHANGING OF PARTS.

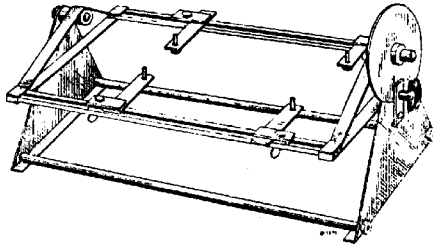

Fig. 7

General instructions.

1. After repair the course of the wiring and the position of the screening partitions must be brought into the original position.
2. Make sure at the same time that the wires are sufficiently far apart (at least 3 mm) from each other.
3. After repair replace in their original position spring washers, insulating material, etc.
4. As a rule rivets can be replaced by screws and nuts.
5. Moving parts may be slightly greased by means of a little pure vaseline.
6. Where necessary and possible, give contacts some mechanical pre-tension.
7. Solder as quickly as possible so that the parts themselves heat up as little as possible.
8. Condensers immersed in compound must be soldered at a distance of at least 1 cm from the compound, to prevent melting away of the compound and bad contact in the condensers. These condensers must be suspended free from the other wiring.
9. In view of the heat development of resistances, the latter must be mounted in such a manner that they do not touch any other parts.

Removing the chassis from the cabinet.

1. Remove the knobs.
2. Unsolder the connections between chassis, L.S. transformer and bottom-screening.
3. Unscrew the 2 screws in fig. 14 indicated by pos. 39. The escutcheon can be removed then.
4. Unscrew the 6 wood-screws with which the scale is fastened to the cabinet.
5. Remove the 4 threaded sockets on the underside of the cabinet by which the chassis is fastened.
6. Remove the chassis out of the cabinet.

Do not lift the chassis by taking it at the coils. Repairing and trimming will be greatly facilitated by the use of the universal chassis holder (see fig. 7).

The chassis is secured to the holder by four screws, and it can then be rotated about its longitudinal axis and can also be secured in any predetermined position with the aid of the brake-disc at the side of the chassis holder. It can be adapted for chassis

of varying dimensions.

For fixing the scale when the chassis is taken out of the cabinet a clamp following fig. 8 is preferable.

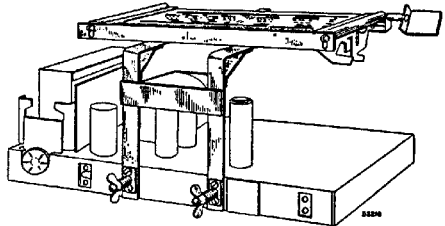

Fig. 8

Coils and trimmers.

The coils and trimmers are fixed to the chassis by means of tags which form part of the chassis. After the connections have been unsoldered the coil or trimmer must be pulled carefully from the chassis. A new coil or trimmer can be mounted with the aid of a pair of pliers.

If the tags have been broken off, the part must be fixed by means of a clamping plate.

Description of the wave-band switch

Fig. 9

The waveband switch consists of one or more units, an arresting plate for establishing the number of positions, spindles, springs, etc.

A unit (fig. 9) consists of a fixed ring, called the stator, a rotor, contact springs b which have to be fixed to the stator by means of the clamps c, one or more springs d which keep the rotor in line with the stator and different types of contact pieces and connecting strips a.

The stator is provided with 24 holes placed in a circle. On the stator side a maximum of 12 contact springs can be attached; between the springs an opening is always left for fixing the contact springs of the other side, so that on both sides of the stator totally 12 contact springs can be fixed.

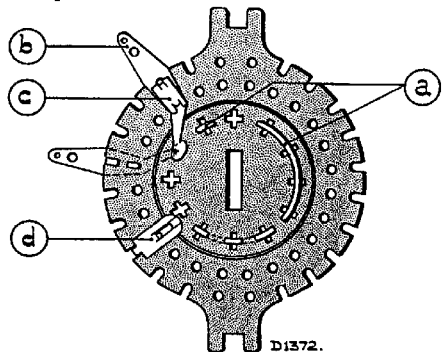
System for drawing the diagram of the switch

In order to give a clear idea of the wavelength switch in the circuit diagram we are giving below a short explanation.

The contact springs on the stator side facing the arresting plate are indicated as open circles in the outer circle. Where there is no contact spring a black dot has been drawn. In all, therefore, 12 circles can be drawn in the outer circle.

In the inner circle 12 circles can also be drawn which indicate the contact spring on the other side of the stator. The interconnecting strips on the rotor side facing the arresting plate are indicated by continuous lines close to the outer circle; those on the other side of the rotor as a dotted line close to the inner circle, whilst contact pieces are shown as a short line between the inner and the outer circle.

The rotor contacts cover one or more holes and on one side all form part of a circle. The contacts are provided with tags which fit into the holes of the rotor and with which the contacts are fixed. This is done by pressing them together with a pair of smooth flat pliers. The pressed tag can also serve for contact on the other side. It is therefore important to make sure that the tag is pressed together in such a way that it is properly flat.

Description of the interconnecting strips in the list of parts

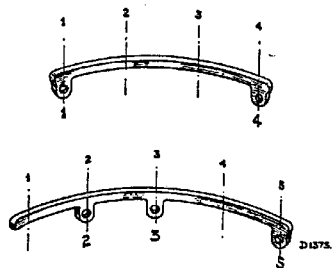

Fig. 10

The connections (fig. 10) can be made in many ways and a special method has been worked out to show clearly the type of connecting strip referred to. The strip is seen from the centre of the circle

of which it forms part. The first figure indicates the number of holes covered, whilst the other figures show in which holes a tag comes, calculated from left to right. Thus, 4.1.4. indicates that 4 holes are covered and that, beginning from the left, holes 1 and 4 are used for fixing and also for contact on the other side.

5.2.3.5 means that 5 holes are covered and that holes 2, 3 and 5 are used for fixing and contacts on the other side. The strips are indicated in this manner in the parts-list, in which way it is possible to immediately find the code number of the required interconnecting strip.

The contact springs of the stator must also be fixed by the service man himself with the aid of clamps which can be done with the same pair of pliers.

LOUDSPEAKER TYPE 9644.

Defects.

1. No reproduction: short-circuit or interruption in voice-coil.
2. Reproduction too weak and distorted: coil jammed.
3. Rustling: dirt in the air-gap, distorted coil, injured cone or too loose connections.

IMPORTANT.

1. When repairing take care for dust and iron parts.
2. The front and rear plates may not under any circumstances be pulled off from the magnet.
3. Replace dust-cover after repair.



Fig. 11

Centring the cone.

This can be done with 4 pertinax calibers which can be inserted between the coil and the core. A new cone can be centered with 4 calibers and fixed with a clamping ring with incisions.

For renewing the cone-carrier a special gauge is required which is placed in the air-gap before loosening the three nuts. Also for centring the cone this gauge must be used.

Sliding cables.

The sliding cables are supplied per meter.

There are 3 different kinds:

1. Driving cable A for driving volume-control.
2. Driving cable B for driving the pointer.
3. Protecting sheath.

Before cutting the driving cables the ends must first be tinned otherwise the strands will turn back. The sliding cables must be handled with great care, as a slight crack will cause already bad running.

It can be cut easily with pliers, but it is necessary to smooth down the ends with a file.

Bottom-tulle.

Before starting the receiver, unscrew the bottom-screws, which are to be reached through the holes in the threaded sockets. The chassis is then mounted elastically in the cabinet, to prevent microphonic effect. When the receiver is sended however, this screws have to be fastened.

Changing the scale.

1. Unscrew the two screws indicated in fig. 14 by pos. 39. The escutcheon can then be taken away.
2. Remove one of the lightning lamps beside the scale.
3. Unscrew the four screws at the edges of the scale about 2 mm. The scale is now to be shifted a little sideways and can be removed.

Changing the vernier unit.

1. Remove the chassis from the cabinet.
2. Loosen the sliding cable from the peg A (see fig. 12).
3. Loosen the set-screw, by which is fastened the crank B to the spindle. (This set-screw is to be reached with a thin screwdriver when the apparatus is switched at the range 16,5-48 m.
4. Remove the clips C and D. The switching mechanism can now be taken away.
5. Remove the screws E and F. (F is to be reached with a long screwdriver from the backside).
6. Remove the four screws with which is fastened the bow H to the chassis. The bow H with the vernier-unit is now to be taken away.
7. Remove the vernier unit from the bow H. (Pay special attention to the spring K).

Changing the cogged-segment.

- 1-6 As 1-6 when changing the vernier-unit.
7. Remove the driving-dum by unscrewing the two screws by which its bracket is fastened to the chassis.
8. Remove the screws fixing the segment to its spindle.
9. Shift the segment from its spindle and remove it on the bottom-side of the chassis.
10. When placing another segment the two parts

must be shifted a little in order to press the three little springs.

Changing the pointer.

1. Remove the chassis out of the cabinet.
2. Loosen the pointer from the steel wire.
3. Remove the scale.
4. File the brims from the ends of the spindle guiding the pointer.
5. Push on one side the spindle out of the hole fixing it.
6. Cut away the tag forming one side of that hole.
7. Remove the spindle through that hole.
8. The pointer is now to be replaced. When replacing the spindle solder it to the brackets.

Changing the waveband-indication.

1. Loosen the two screws indicated in fig. 14 by pos. 39. The escutcheon is then to be taken away.
2. Loosen the sliding-cable from the peg on the L-shaped sheat that moves the waveband-indication-sheat.
3. Shift the waveband-sheat out of its guiding.

Changing the volume-control.

1. Remove the bottom-plate.
2. Unsolder the connections to the volume-control.
3. Loosen the set-screws of the coupling-socket (fig. 15 pos. 40).
4. Remove the screws by which the potentiometer is fastened to the chassis. The potentiometer is then to be removed (pay attention to the spring of the spindle).

Changing the tone-control.

1. Remove the chassis out of the cabinet.
2. Unsolder the connexions the tone-control.
3. Loosen the set-screws of the coupling-socket (fig. 15 pos. 40).
4. Remove the screws by which the potentiometer is fastened to the chassis.
5. Pull the spindle for the volume-control outwards till it is stopped (pay attention to the spring near the volume-control). The spindle is then to be removed by shifting it backward, after which the tone-control is to be removed.

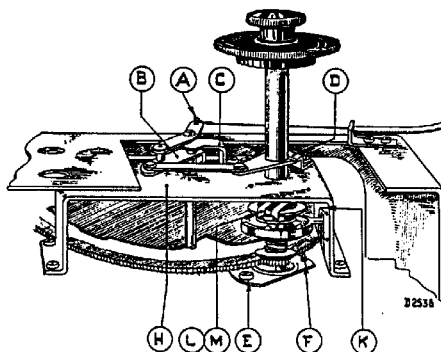

Fig. 12

LIST OF SPARE PARTS AND TOOLS

When ordering spare parts or tools it is always necessary to specify:

1. Code number
2. Type number and serial number of the receiver.
3. Description of spare part, etc.

Fig.	Pos.	Description	Codenumber	Price
		Cabinet	28.245.050	
		Cloth for the L. S.	06.600.970	
		Scale	28.710.310	
		Pointer	25.872.220	
		Escutcheon (color 111)	23.684.273	
		Knob (color 111)	23.610.670	
		Knob (color 111)	23.610.680	
14	8	Plush band (brown)	06.602.770	
14	9	Screening-plate	25.872.200	
14	10	Wave-band-indication-plate	25.872.210	
14	11	Milling-screw	07.742.000	
14	12	Lightning-valveholder	08.515.210	
14	13	House of brake (color 111)	23.660.271	
14	14	Felt-plug	28.478.932	
14	16	Cap for mains-switch (color 111)	28.856.450	
14	17	Mains-switch	28.650.250	
14	18	Valve cap	28.838.740	
14	19	Cog-segment	28.890.510	
14	20	Spring for cog-segment	28.730.820	
14	22	Rear panel	28.402.360	
14	23	Safety contact (color 111)	28.650.262	
14	24	Spring for rear panel	28.752.072	
14	25	Tulle	28.725.372	
14	26	Threaded socket	28.146.401	
14	27	Plate with pins	28.873.200	
14	28	Socket plate	28.873.030	
15	29	Rubber-plug	28.725.410	
15	30	Tulle	25.655.460	
15	31	Tulle	25.655.690	
15	32	Vernier-unit	28.882.430	
15	33	Spindle for volume-control	25.872.190	
		Spring on spindle for volume-control	28.730.930	
		Spring for gramophone-switch	28.740.483	
		Lever for sensibility switch	28.284.050	
12	K	Spring	28.032.960	
12	L	Spring with nave	25.870.170	
		Marking disc	28.711.170	
		Ornamental plate	28.874.090	
		Rotorcontact 2.2	28.904.390	
		" 2.1.2	28.904.142	
		" 3.1.3	28.904.152	
		" 4.2.4	28.904.290	
		" 5.1.5	28.904.240	
		Protective cap for l. s.	28.255.330	
		Ring with incisions for l. s.	28.445.821	
		Paper ring for l. s.	28.445.390	
		TOOLS		
1		Service oscillator	GM 2880F	
		Aperiodic amplifier	GM 2404	
		Universal measuring pin	09.991.622	
5		Universal measuring apparatus	4256	
		Universal- and valvemeasuring apparatus	7629	
7		Universal chassis holder	09.991.380	
8		Scaleholder	09.992.130	

Fig.	Pos.	Description	Codenumber	Price
		Isolated boxspanner 6 mm.	09.992.040	
		Isolated boxspanner 6 mm. without metal parts	09.992.230	
		Isolated screwdriver	09.991.501	
		15°-gauge	09.991.741	
		Centring-gauge	09.991.530	
		Pertinax-calibers	09.990.840	
		Boxspanner 12 mm. (for bottom-screws)	09.992.110	
		Clip for fixing coils	28.080.870	
		Tuning indicator	09.991.590	
		Trimming-transformer	09.992.220	
		Condenser 32000 $\mu\mu\text{F}$	28.199.800	
		Condenser 0,1 μF	28.199.090	
		Condenser 25 $\mu\mu\text{F}$	28.190.070	
		Lever for coils and trimmers	09.991.560	
		Boxspanner for electrolytic condensers	09.991.540	
		Isolated boxspanner 8 mm.	09.991.810	

Spare parts not mentioned here, are taken up in the general list of spare parts.

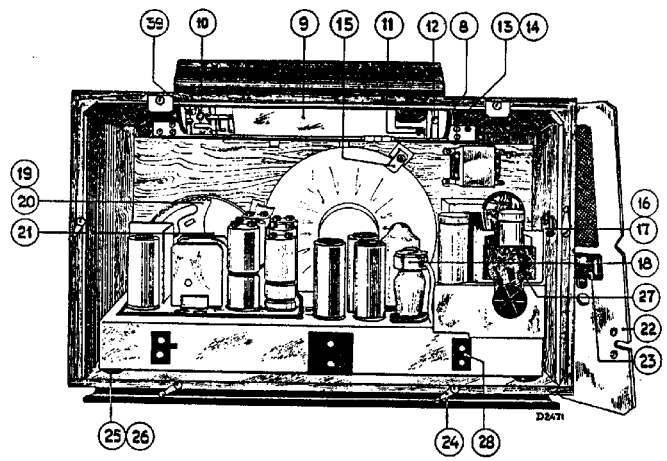

Fig. 14

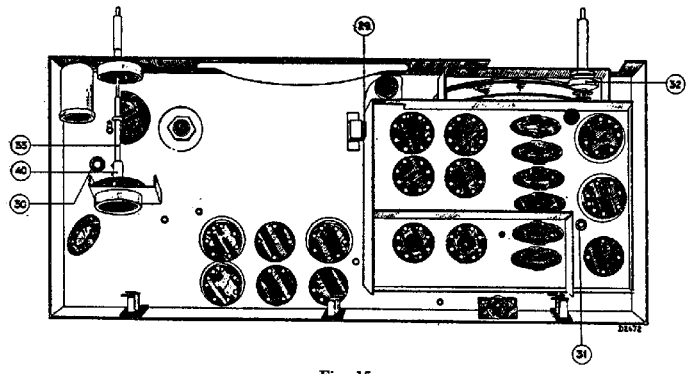

Fig. 15

COILS.

No.	Resistance	Codenummer	Price
S1	200 Ohm	28.533.900	
S2			
S3			
S4			
S5	280 Ohm	28.546.540	
S6			
S7	3 Ohm	28.572.080	
S8			
S9			
C47			
C48			
C49	2,5—30 $\mu\mu\text{F}$		
C50			
S10	7 Ohm	28.572.120	
S11			
S12			
S13			
S14	2 Ohm		
S15			
S16	2 Ohm	28.572.070	
S17			
C6			
C7	2,5—30 $\mu\mu\text{F}$		
C8			
C9	2,5—30 $\mu\mu\text{F}$		
S18			
S19	1 Ohm	28.572.100	
S20			
S21			
S22	460 Ohm		
S23			
S24			
S25			
C12	2,5—30 $\mu\mu\text{F}$	28.572.110	
C13			
C14	2,5—30 $\mu\mu\text{F}$		
C15			
S26	1 Ohm	28.572.090	
S27			
S28			
S29			
S30	7 Ohm	28.570.990	
S31			
C16	12—170 $\mu\mu\text{F}$	28.571.010	
C17			
S32	7 Ohm		
S33			
S34	7 Ohm	28.570.990	
C18			
C19	12—170 $\mu\mu\text{F}$	28.572.190	
S35			
S36	380 Ohm	28.534.640	
S37			
S38	—	28.220.430	
S40	—	28.587.950	

S:	40	1, 2, 3, 4, 5, 6, 7, 8, 9, 10, 11, 12, 13, 14, 15, 16, 17, 18, 19, 20, 21, 22, 23, 24, 25, 26, 27, 28, 29, 30, 31, 32, 33, 34, 35, 36, 37, 38, 39, 40, 41, 42, 43, 44, 45, 46, 47, 48, 49, 50, 51, 52, 53, 54, 55, 56, 57, 58, 59, 60, 61, 62, 63, 64, 65, 66, 67, 68, 69, 70, 71, 72, 73, 74, 75, 76, 77, 78, 79, 80, 81, 82, 83, 84, 85, 86, 87, 88, 89, 90, 91, 92, 93, 94, 95, 96, 97, 98, 99, 100
C:	29	53, 65, 66, 67, 68, 69, 70, 71, 72, 73, 74, 75, 76, 77, 78, 79, 80, 81, 82, 83, 84, 85, 86, 87, 88, 89, 90, 91, 92, 93, 94, 95, 96, 97, 98, 99, 100
R:	29	53, 65, 66, 67, 68, 69, 70, 71, 72, 73, 74, 75, 76, 77, 78, 79, 80, 81, 82, 83, 84, 85, 86, 87, 88, 89, 90, 91, 92, 93, 94, 95, 96, 97, 98, 99, 100

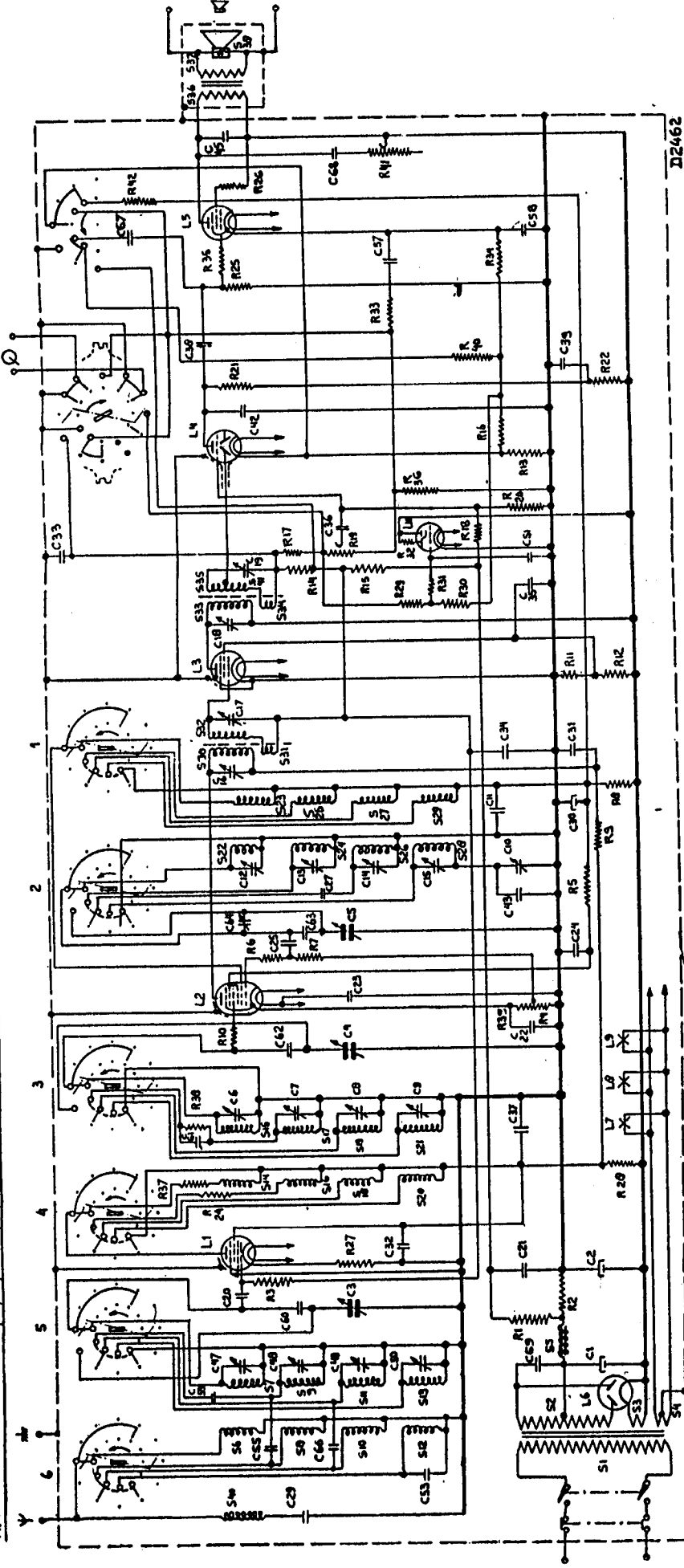

Fig. 17

Fig. 17

RESISTANCES

No.	Value	Codenumber	Price	No.	Value	Codenumber	Price
R1	0,2 M. Ohm	28.773.930		R22	0,1 M. Ohm	28.773.900	
R2	200 Ohm	28.802.560		R24	25 Ohm	28.773.540	
R3	0,8 M. Ohm	28.773.990		R25	0,64 M. Ohm	28.773.980	
R4	500 Ohm	28.773.670		R26	50 Ohm	28.770.120	
R5	80000 Ohm	28.770.440		R27	64 Ohm	28.773.580	
R6	16 Ohm	28.773.520		R28	3200 Ohm	28.770.300	
R7	20000 Ohm	28.773.830		R29	0,64 M. Ohm	28.773.980	
R8	25000 Ohm	28.771.040		R30	0,25 M. Ohm	28.773.940	
R9	50000 Ohm	28.773.870		R31	1,6 M. Ohm	28.770.570	
R10	25 Ohm	28.773.540		R32	2 M. Ohm	28.771.230	
R11	16000 Ohm	28.771.020		R33	160 Ohm	28.773.620	
R12	25000 Ohm	28.803.100		R34	125 Ohm	28.770.160	
R13	9,5 Ohm	28.775.200		R35	1000 Ohm	28.773.700	
R14	3,2 M. Ohm	28.771.250		R36	20 Ohm	28.773.530	
R15	3,2 M. Ohm	28.771.250		R37	50 Ohm	28.773.570	
R16	32 Ohm	28.773.550		R38	0,64 M. Ohm	28.773.980	
R17	50000 Ohm	28.773.870		R39	125 Ohm	28.773.610	
R18	5 M. Ohm	28.771.270		R40	0,8 M. Ohm	28.773.990	
R19	0,5 M. Ohm	28.812.530		R41	50000 Ohm	28.815.540	
R20	1,6 M. Ohm	28.770.570		R42	0,4 M. Ohm	28.770.510	
R21	0,1 M. Ohm	28.773.900					

CONDENSERS

No.	Value	Codenummer	Price
C1	32 μ F	28.182.400	
C2	32 μ F	28.182.400	
C3	11—490 $\mu\mu$ F	28.212.110	
C4	11—490 $\mu\mu$ F		
C5	11—490 $\mu\mu$ F		
C6	2,5—30 $\mu\mu$ F		
C7	2,5—30 $\mu\mu$ F		
C8	2,5—30 $\mu\mu$ F	see "coils"	
C9	2,5—30 $\mu\mu$ F		
C10	12—170 $\mu\mu$ F		
C11	16000 $\mu\mu$ F	28.211.310	
C12	2,5—30 $\mu\mu$ F	28.199.010	
C13	2,5—30 $\mu\mu$ F	see "coils"	
C14	2,5—30 $\mu\mu$ F		
C15	2,5—30 $\mu\mu$ F		
C16	12—170 $\mu\mu$ F		
C17	12—170 $\mu\mu$ F		
C18	12—170 $\mu\mu$ F		
C19	12—170 $\mu\mu$ F		
C20	100 $\mu\mu$ F	28.206.270	
C21	0,32 μ F	28.201.240	
C22	50000 $\mu\mu$ F	28.201.150	
C23	10000 $\mu\mu$ F	28.201.080	
C24	50000 $\mu\mu$ F	28.199.060	
C25	100 $\mu\mu$ F	28.206.270	
C27	1575 $\mu\mu$ F	28.195.500	
C29	147 $\mu\mu$ F	28.195.380	
C30	32 μ F	28.182.400	
C31	50000 $\mu\mu$ F	28.199.060	
C32	50000 $\mu\mu$ F	28.199.060	
C33	100 $\mu\mu$ F	28.206.270	
C34	50000 $\mu\mu$ F	28.201.150	
C35	50000 $\mu\mu$ F	28.199.060	
C36	10000 $\mu\mu$ F	28.201.080	
C37	0,1 μ F	28.199.090	
C38	20000 $\mu\mu$ F	28.199.020	
C39	0,1 μ F	28.199.090	
C42	320 $\mu\mu$ F	28.190.180	
C43	400 $\mu\mu$ F	28.190.400	
C45	2000 $\mu\mu$ F	28.201.480	
C47	2,5—30 $\mu\mu$ F	see "coils"	
C48	2,5—30 $\mu\mu$ F		
C49	2,5—30 $\mu\mu$ F		
C50	2,5—30 $\mu\mu$ F		
C51	0,1 μ F	28.201.180	
C53	50 $\mu\mu$ F	28.206.240	
C57	1 μ F	28.160.950	
C58	1 μ F		
C59	6400 $\mu\mu$ F		
C60	214 $\mu\mu$ F	28.195.730	
C61	214 $\mu\mu$ F	28.195.490	
C62	6400 $\mu\mu$ F	28.195.730	
C62	214 $\mu\mu$ F	28.195.490	
C63	214 $\mu\mu$ F	28.195.490	
C64	214 $\mu\mu$ F	28.195.490	
C64	2,5—30 $\mu\mu$ F	28.211.320	
C65	2 $\mu\mu$ F	28.205.880	
C66	2 \times 2 $\mu\mu$ F	28.205.880	
C67	3200 $\mu\mu$ F	28.198.940	
C68	50000 $\mu\mu$ F	28.201.640	
C69	20000 $\mu\mu$ F	28.201.650	

VALVES

L 1 EF 8	L 2 EK 2	L 3 EF 5	L 4 EBC 3	L 5 EL 3
L 6 AZ 1	L 7 8045-37	L 8 8045-37	L 9 8045-07	L 10 EM1

S:						41, 33, 34, 35,		32,		6, 7, 8, 9, 10, 11, 12, 13,
C:	57, 59,	36,	51, 33,	30,	68, 42,	38, 21, 67, 18, 19,		34,	17, 39, 35,	45,
R:	33, 36,	29,	41, 19,	17, 20, 31, 30,	40, 42, 16, 13, 25, 34, 35, 2,	8, 18,	26,	12, 28, 1,	45, 14, 21, 22, 11,	

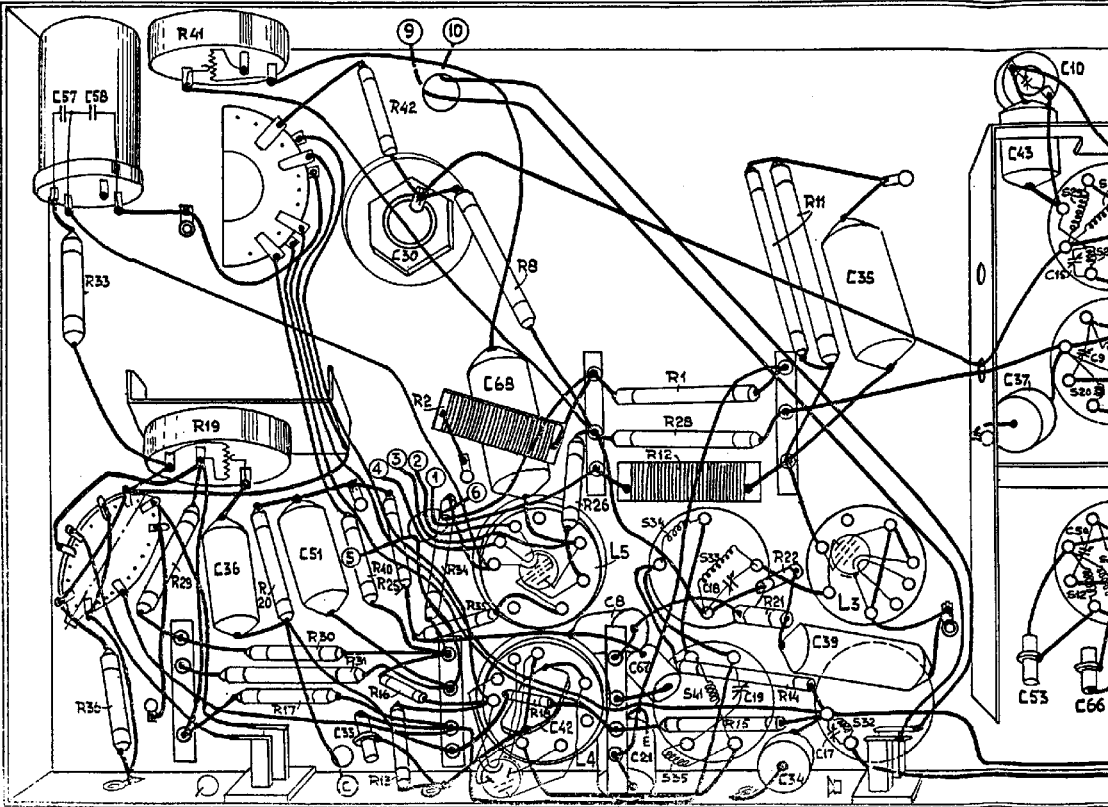

Fig. 16

52.	6, 7, 8, 9, 10, 11, 12, 13, 14, 15, 16, 17, 18, 19, 20, 21, 22, 23, 24, 25, 26, 27, 28, 29.	40.	50, 51.
34, 17, 39, 35, 45	50, 43, 40, 37, 53, 66, 89, 44, 9, 15, 65, 13, 45, 7, 11, 6, 27, 61, 59, 47, 42.	29, 3, 4, 5.	60, 63, 62, 20, 25, 64, 23, 37, 32, 16, 22, 24.
21, 22, 11.	38, 37, 24.		9, 3, 6, 5, 7, 27, 4, 39.

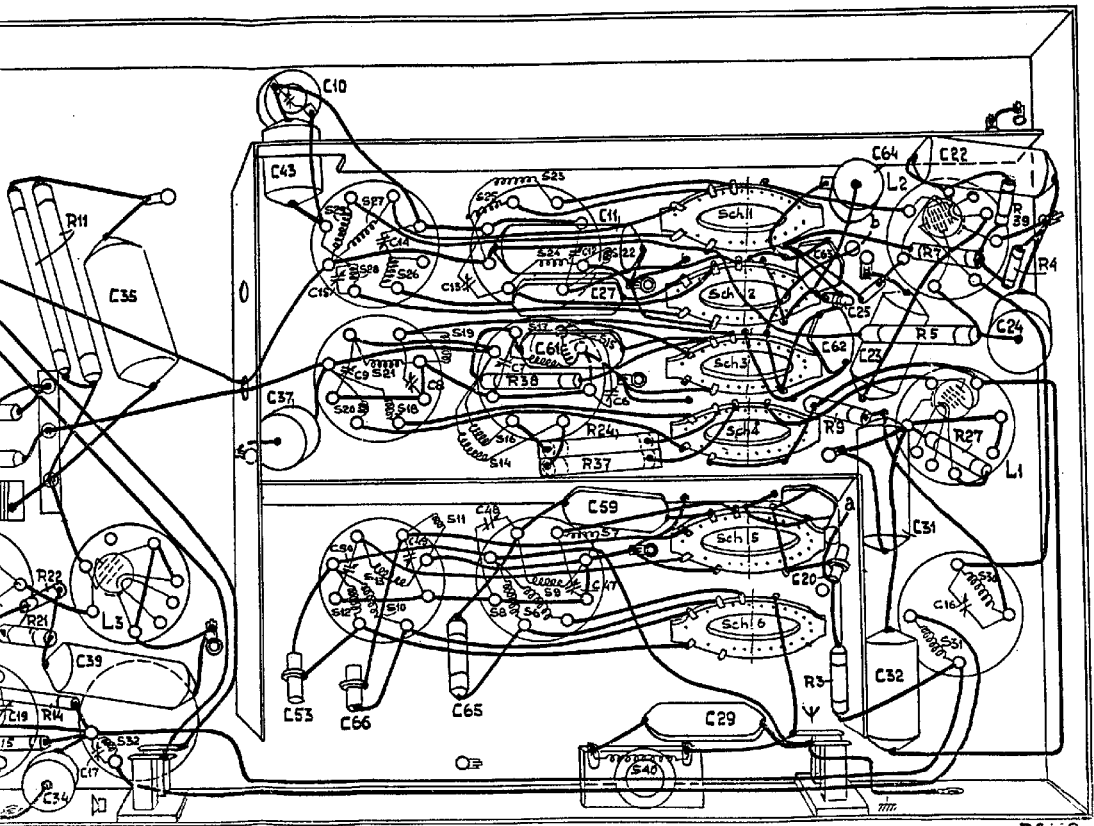

Fig. 16

D2469

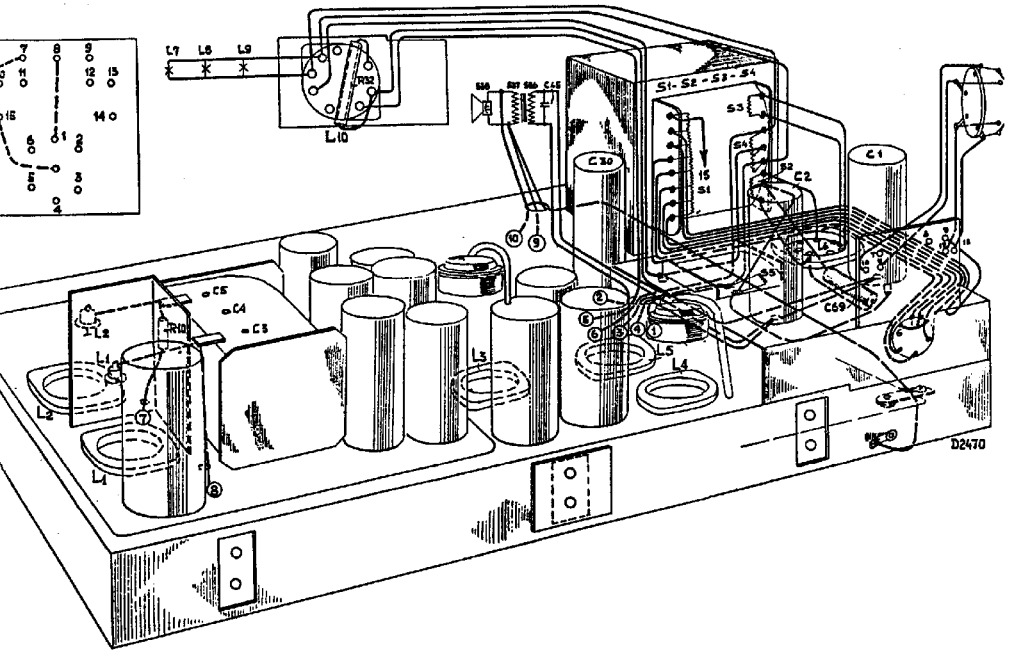

Fig. 18

TENSIONS AND CURRENTS

	normal	foreign		normal	foreign	
Va	247	224 V	ia	4,1	7,8	{ L1
V3	250	227	i3	0,12	0,19	
Va	212	192	ia	0,72	0,69	{ L2
V3,5	50	49	i3,5	1,11	1,06	
V2	147	147	i2	3,1	3,1	
Va	267	256	ia	3,95	8	{ L3
V2	88	74	i2	1,04	2,1	
Va	102	98	ia	0,78	0,75	L4
Va	246	237	ia	34	34	{ L5
V2	260	250	i2	4,8	4,7	
Vscreen	266	257	ia	0,11	0,11	L10
V.C1	295	287				
V.C2	266	257				

Total primary consumption 60 W.

These voltages are measured in respect of the chassis with the voltmeter having a resistance of 2000 Ω per Volt.

The above values are averages taken over a large numbers of receivers and a certain amount of

deviation may therefore be met with.

If voltmeters are used of which the internal resistance is less, then the values obtained are generally speaking lower.